

FREIGHT CARS

NUMBER
10

JOURNAL



July 1, 1985
ISSN 0742-9355

\$ 2.50
Double Page Issue

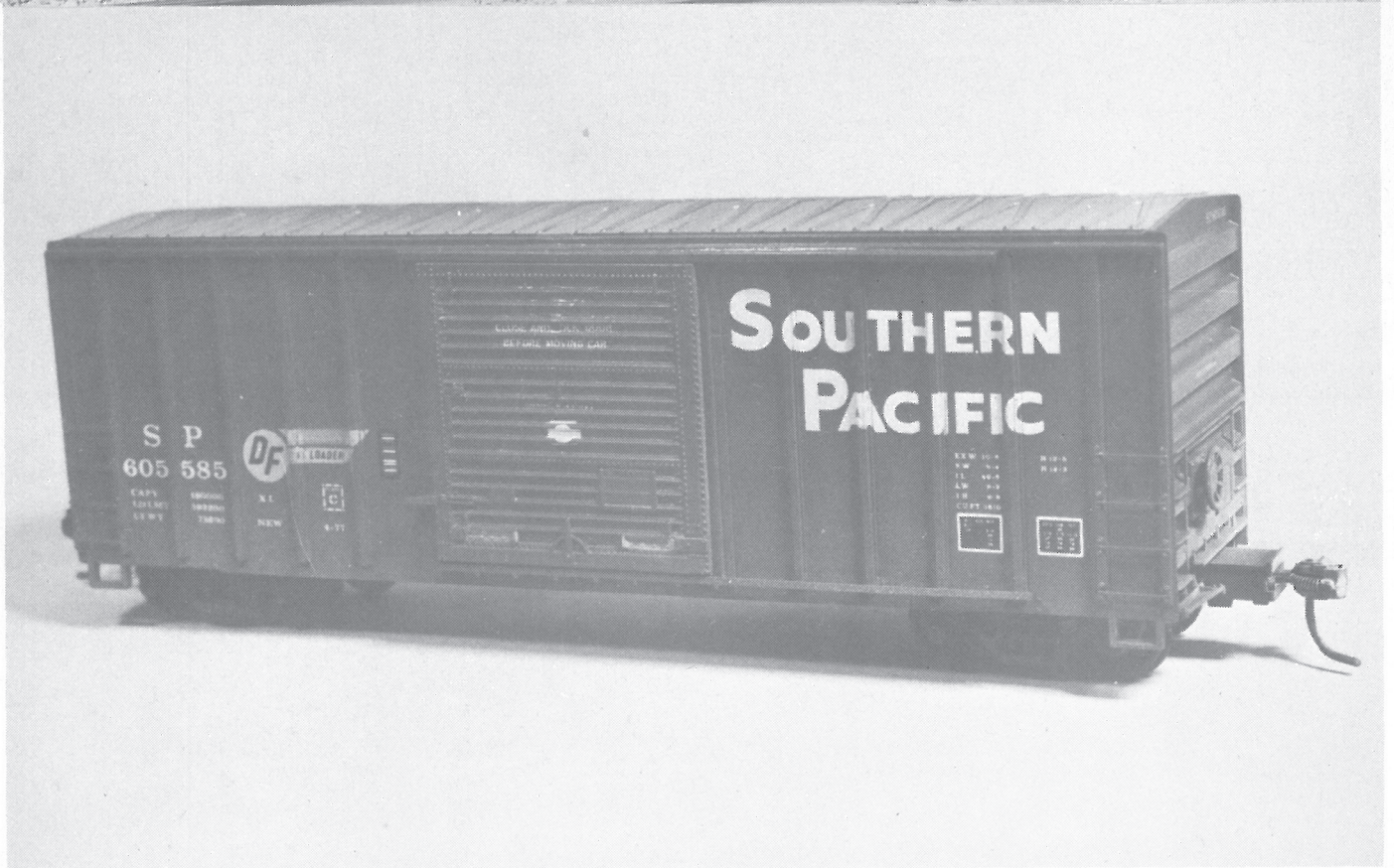

FREIGHT CARS JOURNAL

Vol.2 #6

Issue 10

July 1, 1985

FEATURES

MODELING THE SOUTHERN PACIFIC 605550-605699	
MODERN FORTY-FOOT 100 TON BOXCAR IN H.O. SCALE	
Staffan Ehnbonm.....	5
READING CO. EIGHT-WHEEL CABOOSE	
Eric A. Neubauer.....	11
UTILITY FUELS, INC. ALL TIME FREIGHT CAR	
ROSTER 1978-1985.....	17
FMC PORTLAND PRODUCTION LIST Part 6.....	18
SOUTHERN PACIFIC TRAIN CONSISTS:	
Part I The CZLAT Trains - Pat A. Holden.....	19

COLUMNS

FROM THE EDITOR / ANNOUNCEMENTS.....	4
RECENT DELIVERIES & ACQUISITIONS.....	7
THE CABOOSE COLUMN.....	10
FCJ ADDITIONS AND CORRECTIONS.....	10
RECENT FREIGHT CAR HISTORY LITERATURE.....	10
THE MODELER'S COLUMN - Byron S. Rose.....	15
FREIGHT CAR LOCATER - Richard Yaremko.....	16
BUILDER'S PRODUCTION AND DESIGN NOTES.....	17

ACKNOWLEDGEMENTS

We would like to thank those individuals that help make this issue of Freight Cars Journal possible: Staffan Ehnbonm, Robert Landregan, Carl W. Shaver (CWS), Stuart H. Thomson (SHT), Don McQueen (DM), Joe Fishbein (JF), Craig T. Bossler, Byron S. Rose, Richard Yaremko, John Riddell, James Eager, Robert Warren, J.R. Quinn, Eric Neubauer (EAN), Pat Holden and David G. Casdorff (DGC).

COVER PHOTOGRAPHS

FRONT COVER: Union Pacific 500002 a 50'6" offset double door interior post loader equipped boxcar (XML) built in April, 1953 by the Union Pacific's Omaha Shops. Union Pacific class A-50-21. This 50 ton boxcar is from the series UP 500000-500199. The car is specially equipped with 9 belt DF loader equipment inside (to help secure the car's load from shifting etc.) Note the side sill architecture with the "notch" located under the end side-panels. The later A-50-23 and -24 classes apparently did not have this feature. (U.P.R.R. Photo/ Robert Warren Collection)

INSIDE FRONT: (Top) SP 605588, a 40'6" loader equipped boxcar built in 1977 by FMC. SP Class B-100-41. (Jim Eager photo)
(Below) H.O. Scale model of SP 605585 built by Staffan Ehnbonm. See article beginning on page 5. (Photo by Staffan Ehnbonm)

EDITORS

DAVID G. CASDORPH
ERIC A. NEUBAUER

ASSOCIATE EDITORS

JIM EAGER
PAT HOLDEN
AL TUNER
RICHARD YAREMKO

COPYRIGHT (C) 1985 MTHS

ISSN 0742-9355

All Rights Reserved

\$12.00 per year
Published 8 Times/Year

Please Make Checks
Payable To:

MODERN TRANSPORT
TECHNICAL & HISTORICAL
SOCIETY
(M.T.T.H.S.)

DUES/SUBSCRIPTIONS
Should be sent to:

DAVID G. CASDORPH
P.O. Box 1458
Monrovia, CA 91016

BACK ISSUES

N° 1	16 pp.	See
N° 2	28 pp.	Announcement
N° 3	24 pp.	SOLD OUT
N° 4	36 pp.	SOLD OUT
N° 5	40 pp.	\$3.75
N° 6	16 pp.	\$2.25
N° 7	12 pp.	SOLD OUT
N° 8	20 pp.	\$2.25
N° 9	16 pp.	\$2.50

* Prices include postage

MEMBER'S EXCHANGE

Dan Sanger, P.O. Box 14-18232, Boise, IDA 83707 is looking for photos, diagrams, info for modeling purposes of wood outside braced boxcars/ automobile cars of the C&NW, MP Lines, Northern Pacific and SL-SF (Frisco).

FROM THE EDITOR / ANNOUNCEMENTS

First, my apologies for this slightly late issue. The camera store that I was having prints made for the Journal went out of business. This not only left me with having to find somebody else but also having to re-train that someone once I found them. It took me about a week to find someone. Then it took nearly three weeks and several returns of the prints to get them correct. All I had was the cover photo (thank goodness) and fortunately Staffan's article came in. So, to try to avoid this again and to give a little more time between issues I've adjusted the publication schedule slightly.

NEW PUBLICATION SCHEDULE

Basically, we will print it approximately every 45 days. The new scheduled dates are as follows:

January 1st	July 1st
February 15th	August 15th
April 1st	October 1st
May 15th	November 15th

I think this will help "even" things out a little as well as provide more time for our column editors.

NEW INDIVIDUAL ISSUE PRICES

Because of a variable input of articles our magazine has a variable number of pages. I suppose I could hold off articles for several months on end to work them in....but, I feel this is not fair to the authors. The authors spend many hours preparing their articles I feel we should publish your article as fast as possible. Thus the reason for variable number of pages. To date, articles submitted have been published within two issues (usually the next) from the time it was received. With a variable number of pages comes a variable cost and so to compensate for that we present the following price schedule:

12 page issues= \$1.75	20 page issues= \$2.25
16 page issues= \$2.00	24 page issues= \$2.50

The yearly subscription price will remain at \$12.00 per year.

HELP! ARTICLES NEEDED

We're always interested receiving articles for publication in F C J of any era or railroad, prototype or scale model. However we are in special need of articles on freight cars of the 1900 to 1959 era. There's an interesting "catch-22" situation here. Many of the FCJ members have expressed their interest in this 1900-1959 era ...yet very few have taken the time to share their interests and knowledge in this era of

freight car history. Some have even questioned why we emphasize the "modern" era so much. My answer is we can only publish what we have material for.....So, what I'm asking is...if you're one of the lucky few people that has information and photos of this era.....please take a little time to share some of it with the rest of us!

REPRINTS OF FCJ #'s 1 & 2

If you would like a copy of FCJ issues 1 and 2 ...now's the time. Cost will be \$3.50 each including postage. They'll be photocopies unless we can get enough orders to have it offset printed (only need 75 orders). I believe there were only 44 pages total between the two issues. Please if you could even order extras....I'd much rather have them offset printed than photocopied.

FCJ MONOGRAPH #1

FMC BOXCARS SINCE 1972

Eric Neubauer has recently completed the manuscript for our first monograph. This is an excellent book for modern boxcar historians. The book will be softbound, 32-36 pages and include 8 glossy pages of both builder photos and never-before-published in-service photos of various boxcars built by FMC during this time period. Text includes physical descriptions of the various designs, alpha roster, production roster, color identifier list, modeling, second and third hand renumberings, production totals etc. Details of types of doors, ends, cushioning devices etc. used on various cars. Also an O scale center piece drawing. This is available for a pre-publication price of \$7.50 (before August 31, 1985) thereafter price will be \$9.50.

RENEWALS

If the number in the right hand corner beside your name on the address label is "11" its time to renew. Membership form enclosed.

FREIGHT CAR FUN

Zoologists often have special names for groups of certain animals. So too, we freightcarologists should have special names for groups of particular freight car types. So we might see "bands of boxcars" roaming the countryside or "gaggles of gons" flying past the crossing gate. Watch out for "troops of tankers" invading the local yard. I've even seen "flocks of flats" with farm tractors on them and there are more "litters of pigs (or piglets)" than ever before. And if that's not enough you better watch out for those "packs of racks" (auto racks that is....)

MODELING THE SOUTHERN PACIFIC SERIES 605550-605699 MODERN FORTY-FOOT 100-TON BOXCAR IN H.O. SCALE

By Staffan Ehnbohm

The new Southern Pacific 40' box cars of the 70's mentioned in FCJ #4 are tempting to model. Modeling the B100-32 series 605000-605299 and 605300-605549 with diagonal panel roof and dreadnaught ends built by PC & F in 1972 and 1974 is shown in an admirable Protofile article by Jim Eager in the April 1983 issue of the Railroad Model Craftsman. In this article I am trying to show a way to model the even more modern B-100-41 series 605550-605699 with X-panel roof and nonterminating "square" ends built by FMC in 1977.

The first step in modeling this car was to secure a good 3/4 view photo of the prototype car. In this case I borrowed a slide of the 605551 by Joseph R. Quinn from Dave Casdorff's Collection.

The next step was to secure correct lettering as used in the prototype picture. The 605551 has a small crossbar loader sign that isn't available in this small size in the three Microscale SP and SSW lettering sets that I had available. Also there is the FMC builder's plate that will have to be found elsewhere. Otherwise the car has rather standard SP lettering, so the project can be started.

It is reasonable to believe that the 40' box cars were pretty much shortened versions of the 50' cars of their time. As there is a model of the contemporary 50' box car available from MDC (50' single door box car # 1950), a study of this kit is a good starting point.

A common problem in exact modeling of box cars is the lack of good pictures of what the roof panels look like. In the shot of the 605551 it is possible to see that the roof panels are of the "X type". But it is possible that the panels at the end of the roof have no pattern in them. The car ends look the same on the 40' and 50' cars, of course. On the car sides, however, the side posts are spaced closer together on the 40' cars than on the 50' cars. So I couldn't use the sides as they are. The 10' improved corrugated door is the same as on the SP 40' car, though.

The shortening of the 50' body can either be accomplished by removing a 10' section from the center and refitting the end pieces for a 40' body or one can go the more complicated route of removing a 5' section from either end thus retaining the original, correct, cast in place doors, but having to refit both ends to the remain-

ing center piece of the body. Partly because of the single refitting of the body pieces and partly because of my preference for operational sliding doors, I chose the former route.

While the 50' body was still intact, I removed details like the door guides and door tracks, the side grabs and all side posts except the ones the side grabs had rested on and the ones that would disappear, when new door openings were made. The step in the side sill was also removed. Then the body was cut along the sides of the doors and across the roof right through the center of the respective X panels. Then half of each 10' door opening was cut into each body half leaving the side sill in place. Then the halves were fitted and cemented together and strips of styrene were cemented across the joint in the roof.

For the side posts I cemented 2" x 3" Evergreen styrene strips to 1" x 6" strips like a hat section. 11' lengths of the "hat section" were then cemented to the sides on approximately 2'6" intervals. The door posts were built up from 1" x 12" and 2" x 8" strips. New side grabs were made from plastic rodding. A 15" length of 1" x 2" styrene strip was added to the end ladder center risers. Lift bar brackets from a Cal Scale Hydra-Cushion kit were added.

The Athearn Railbox door looks like the doors I needed except the slightly taller door of our prototype has one additional corrugation in the top panel. To accomplish this, I cut off the top including one complete corrugation from one door. Then I took the top including two corrugations from the second door and fitted this top piece to the first door. From a third door I cut the top including three corrugations and fitted this to the second door.

I made a top door guide by cementing a 2" x 2" strip to a 1" x 3" strip. This door guide was cemented to the top of the side with the 1" x 3" piece extending downwards so as to retain the lip at the top of the Athearn Railbox door. A 2" x 2" strip was cemented along the rear of the bottom edge of the door for a similar lip to hold the door in the door track. The door track was made from a 2" x 3" cemented to a 1" x 3" and cemented to the outer face of the side posts. Patience and a high quality cement is required for this operation. Blocks of 2" x 2" strip are cemented to the underside of the door track.

For the underbody I glued an Athearn 40' floor weight to a floor made from a 9'3" x 40'2" sheet of thin styrene. A Details West 50' underframe was shortened to an approximate 31' truck king pin distance and Athearn three coil trucks and the underframe were secured to the floor with screws and nuts. Check the picture of the prototype car and the pictures in James Eager's article for information on the underbody brake gear.

The underbody and the insides of the side sills were painted grimy black. The sides and ends were painted box car red. The red was carried over the top of the ends and the sides to the small ridge about 3" in from the edges of the roof. This was my guess of what the prototype might have done from looking at a pile of roof top views of other SP box cars. The roof was then painted to look like galvanized iron (a 50/50 mix of Floquil silver/ reefer gray).

Microscale decal set no.1: Roman style data is used for data, C & ACI plates. No.3 SP freight is used for the road name, initials and numbers. No. 219: Cotton Belt freight. is used for the small DF loader sign retaining only the word "loader" from the top bar, the feathered ends of the bars and the circle with the "DF". New bar segments

were made with the help of Champ yellow decal stripes. These were also used to mark door push areas at the bottom of the doors. Champ consolidated stencils were also used.

A D D E N D A

After completing my model I learned from Jim Eager that the second end rib from the bottom is wider than the other end ribs. There is a DF Crossbar Loader sign in Microscale set no. 258, but it seems a little too large for this car. FMC logos are available from Herald King. As far as roof color, Jim points out that today most builders and railroads are not painting the galvanized metal roofs. Jim suggests feathering the car color out to the roof seam to represent overspray rather than a hard mask line.

Staffan Ehnbon

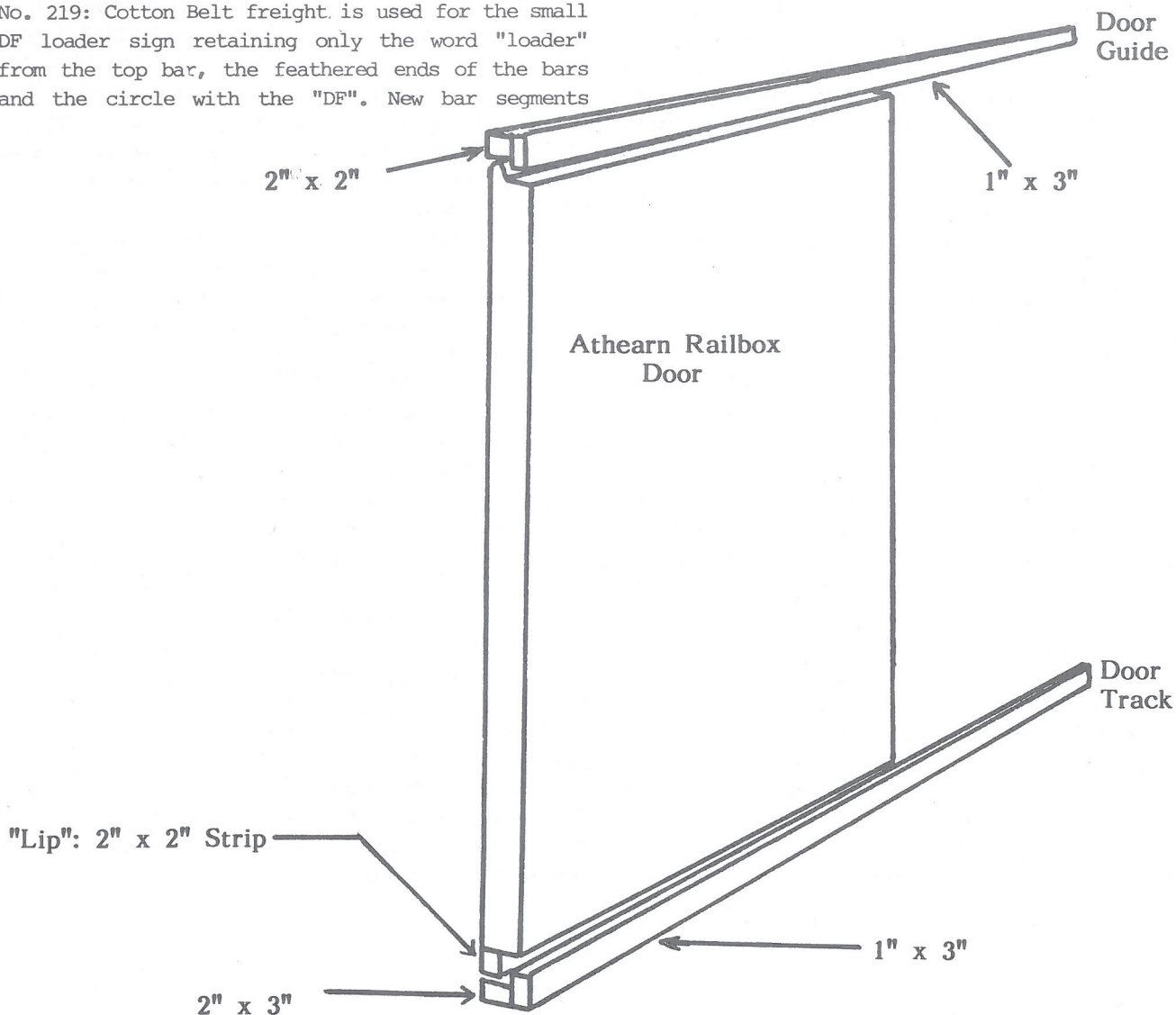

RECENT DELIVERIES & ACQUISITIONS

CLASS I & II RAILROADS

BURLINGTON NORTHERN has acquired sixty-five 50'6" high-cube double door special products boxcars (XP) from the Valley and Siletz RR series 2000-2149. The cars remain in VS green with white reporting marks and logos painted over in BN green.

Also acquired earlier last year were some ex-Milwaukee Road auto racks (on ETTX flats) BN's rack numbers on these are in the low 5000s (BN 5006 on ETTX 850405).

The BN has also ordered some five train sets (so far) of the new design Gunderson built double stack articulated container cars to be delivered June through August of this year.

What did the BN run out of green paint? Recently spotted was BN 564471 a 100 ton gondola painted black with all data, lettering and logo done in white. Repainted by the St Cloud Shop in December 1984. (CWS/SHT/DGC)

CANADIAN NATIONAL has ordered 150 fully enclosed bi-level auto racks to be built by Hawker Siddeley of Trenton, Nova Scotia.

Also those 52 articulated five-platform intermodal cars mentioned in FCJ #8 are being built by National Steel Car. (DM)

CHESSIE SYSTEM B&O/C&O has placed some new series of RBL-reefers in service this year (as part of a trade in arrangement) from Fruit Growers Express. The C&O is to get 128 (numbers 402000-402089 and 403000-403037) and the B&O is getting 222 (numbers 402090-402234 and 403038-403114) All of these are being painted in the recently introduced (a few years ago) Solid Gold paint scheme. These cars are not new built. They are used cars previously lettered for the Fruit Growers Express and the Penn Central. (CWS/C&O Newsletter)

CHICAGO & NORTH WESTERN also joins the "new auto-rack club" with the introduction of some new April 1985 built bi-level auto racks from Thrall Car. These are placed on Trailer Trains TTGX flats (examples: TTGX 254804, 254969 and 255099) (CWS)

CHICAGO SOUTH SHORE & SOUTH BEND recently acquired 25 ex-San Luis Central 50'6" single door special-products boxcars (XP) (originally built by FMC in 10-79. They are from the SLC series 1000-1099. New numbers are CSS 1601-1625. (CWS)

FLORIDA EAST COAST has recently placed in service a number of new 45' long 102" wide piggyback vans built by Brae. Numbers sighted so far have been between FECZ 630171-630321 (these are NOT the series number limits) (DGC)

ILLINOIS CENTRAL GULF has received fifty 50'6" single door boxcars apparently from the Lake Erie, Franklin and Clarion early this year. The new ICG series is 503400-503449. Cars were originally built new by USEX in March 1979. (DGC)

GRAND TRUNK WESTERN is rebuilding one-hundred 60'8" single door auto parts boxcars from the 383000-383248 series (built by ACF in late '65 early '66) into hi-cube auto parts boxcars. The rebuilt cars have had the roofs raised 20 inches. The new rebuilt series is numbered GTW 384000-384099. (examples 384014 built 12-65 rebuilt 12-84; GTW 384086 rebuilt 1-85). (CWS/EAN)

Some additional information and built dates on those new auto racks mentioned in FCJ #9. There apparently will be 250 of these with rack numbers (not road numbers) 85001-85250. So far build dates spotted up to #85199 are 3-5-85. (DGC)

NORFOLK & WESTERN: an additional build date on their new tri-level auto racks of the class Ft-56. N&W rack # 5087 built by Thrall Car in 3-1985. By the way, these racks have the "clam-shell" type of end doors. (DGC)

SEABOARD SYSTEM along with the Norfolk Southern has become the first U.S. railroad to employ new length 48' piggyback vans. Sighted SBDZ 610198 built by Miller. The vans are 48' x 102" and have a 3427 cubic foot capacity. These vans have the rust-red number plates and trim colours of XTRA, so I assume they are probably leased from them.

Many of Seaboard's RDSZ prefixed reefer piggyback vans from the 540000 and 540500 series are showing up in new reporting marks. Various numbers from both series are appearing with a new reporting mark "VEGZ" and others are showing up in the Agricultural Xpress of America marks "AXXZ". (these were originally mentioned in FCJ #7).

Another ex-reporting mark for the SBD is SBD 162234 from The Seattle & North Coast series 1100-1299. These are Pullman Standard 50'6" 5344 cubic foot boxcars.

Still more "ex's" is the SBD 135744-135765 series. SBD 135750 is ex-Rahway Valley RR 50'6" single door boxcar built by USEX in 3-80. (DGC/CWS/EAN)

SOO LINE is still picking up a mixture of ex-Pullman Leasing covered hoppers. This includes 230 random numbers from the Pullman Leasing 31851-34999 series not renumbered and placed into the Soo Line series 33116-34963. These are Pullman-Standard built 4750 cube covered hoppers.

Another series Soo 84013-89182 are also ex Pullman Leasing. These have been renumbered but only the first number was changed and the '8'

added in its place. So far there are 184 random numbers in this series. These too are Pullman-Standard 4750 cube covered hoppers. The cars still have the original livery and logos of their former lessees. (JF)

SOUTHERN PACIFIC is currently (or just completed) adding a number of new special equipped 45' long 102" wide piggyback vans. Numbers sighted so far range from SPLZ 936678 to 937403. These are Brae built galvanized steel vans (model GSVW-Z-454T-S). So far only a 3-85 build date has been spotted.

The B-70-42 and -43 paper boxcars continue to be rebuilt by the SP. The highest number sighted now is 226330 with a 4-85 rebuilt date (Series begins at SP 226000).

Business on the CIPXX "Sun Pig" sprint train has increased and the piglets have grown up to full sized pigs. The formerly pure single-axle single-van TTUX consist train now has nearly all standard 89' piggyback flats.

Rebuilt container flatcar class F-70-46C continues to be outshopped from Cotton Belt's Pine Bluff Shops. The latest dates include 4.85 and 5.85 (rebuilt dates) with numbers up to SP 910250.

Still another new class of rebuilt container cars appear. Class F-70-46D. SP 901545 rebuilt 5-85 by the Southern Pacific Roseville Shops.

SHORTLINE RAILROADS

MARYLAND MIDLAND RWY acquired Hartwell Railway's HRT 100-142 series originally delivered to the New York, Susquehanna and Western RR by CNCF (Mexican builder) as NYSW 100-142. Maryland Midland's new series retains the original numbers (now MMID 100-142) these are 50'6" general-service boxcars.

MMID 1004-1014 another series new on the MMID. These were built by United American in 1979 and were originally Pittsburgh, Allegheny and McKees Rocks Railroad. These are 50'6" boxcars.

Lastly, another series of "ex" cars is the 20010-20011 50'6" boxcars originally built for the Vermont Central by Berwick in 1976. (EAN/CWS)

NASHVILLE AND ASHLAND CITY RR added a new series of 45' piggyback vans to their roster. The series apparently starts at 634400. They were built by Miller in October 1984 and are leased from PLM. (DGC)

SABINE RIVER & NORTHERN added a third series of 50'6" single door boxcars to their fleet. The new series numbered SRN 5400-5449 are ex New Orleans Public Belt cars built by Pullman-

Standard in 12-79 (lot 1009). These are PS's standard 5344 cubic foot design car. (EAN)

VERMONT RAILWAY is getting some used vented high-cube 40' containers (ISO 4510) leased from Interpool. These are apparently renumbered and re-lettered from a previous lease. They are gray containers with a large freshly painted green and white Vermont Railways rectangle logo on the sides. Example IVTZ 204540. (DGC)

WATERLOO RR has been active with used boxcar acquisitions. WLO 503100-503199 a series of 100 50'5" single door boxcars from the Pickens 55200-55299 series built by Golden Tye in 1975. The interesting thing on this series is that they have been repainted by the Southern Rwy in 1985 in Southern Boxcar Red.

Another new series is the WLO 502838-502851. WLO 502839 was built for the Peninsula Terminal by Southern Iron & Equipment in 1979.

PRIVATE OWNERS

ADM TRANSPORTATION added a second series of alcohol tankers this year. The new built tank cars were built by ACF's Milton plant 1=3-85 and are numbered ADMX 29351-29450 (total 100 cars). All are circa 30,000 gallon AAR type T108 tankers. (DGC)

AMERICAN PRESIDENT LINES continues to add more of the Thrall built articulated double stack well container cars. New numbers have been sighted up to APLX 2160 with build dates of 3-85 and 4-85. This new group are all stencilled Thrall Car Job # 853. Also this group weighs a little less than previous sets. All of the cars spotted so far in this series have a light weight of 153500 lbs. (versus the other 155000 lbs.) These are blue cars. No further of the generator unit "red" cars have been sighted yet.

Also APL is adding more 45' high-cube containers in the series APLU 452670. Previously these containers (the only of its kind in the U.S.) have been built by Nippon Fruehauf. This new series however is built by Nippon Trailmobile so far in 3-85 and 4-85. These are model CDS-EA4501, ISO type 9510. (CWS/DGC)

CONTINENTAL GRAIN CO. has their own reporting marks and cars now. Their first series numbered CGCX 20000-20699 are all ex-Pullman Leasing Pullman-Standard built covered hoppers (4750 cube design) (DGC)

CORNUCOPIA TRANSPORTATION added some new built piggyback reefer-vans this year. These are Fruehauf built. Examples: CRAZ 537109, 537188, 537243 537248. (DGC)

DEPARTMENT OF DEFENSE added another series of 68' special purpose heavy capacity flat cars built by Ortner. The new series DODX 40245+ have been sighted numbered up to 40358 with build dates of 2-85 and 3-85. They have a nominal capacity of 301000 lbs and weigh circa 97500 lbs empty. (EAN)

E.I. DUPONT DE NEMOURS have added quite a few new tank cars in the last year. One series that has been sighted is the DUPX 27001-27034 AAR type T615 refrigerant gas tankers built by Union Tank in June 1984. Cars have white tanks with black data. (DGC)

GENERAL AMERICAN TRANSPORTATION though out of the car building business is certainly keeping Trinity Industries busy this last year or so.

A group of insulated 16,750 gallon tankers were built for lease to Diamond Shamrock Chemicals by Trinity, Fort Worth. Number range sighted so far go from GATX 22268 to 22311 with build dates of 1-85 and 2-85. The cars are lined by Trinity with Plaschem 2310. Black tank/white lettering and data.

Airslide covered hoppers continue to be built. Recently sighted was GACX 56362 built by Trinity in 2-85 for lease to International Multi Foods.

A group of tankers that were originally built by General American in 1-2-80 are being reconditioned, repainted, new lining added for Coconut Fatty Acid service for Proctor & Gamble. GATX is doing the work with rebuild-overhaul dates of 4-85 and 5-85 so far. Car numbers of this group sighted so far are GATX 23502/23539.

Another group of new built cars are GATX 17848-17867 built by Trinity in 9-84 for solvents service with Union Oil of California. These are 200 ton tankers with a capacity of circa 26,750 gals. (DGC/CWS)

GREENBRIER LEASING CORP. is on the go....in addition to all of those rebuilt container cars leased back to the SP they are now in the process of getting up to 100 of the new Gunderson built articulated-double stack container cars. The first car I've sighted is GBRX 2003 built in 4-85 and is painted a nice bright red with white lettering and data. (DGC)

PULLMAN LEASING CO. also out of the building business (ala Pullman-Standard) is apparently picking up some used covered hoppers built by their former competitor. Recently sighted was PLWX 5707/ built by ACF, Huntington in 12-81. This is a "Center Flow" covered hopper that was formerly lettered for Conoco (CONX). 5700 cuft. (EAN)

SEA-LAND SERVICE is adding four trains of the new Gunderson built articulated-double stack container cars for service from Tacoma to Chicago (and on to New York) this year.

Sea-Land has also been actively adding to their refrigerated container fleet. Including a series of Nippon Trailmobile refrigerated containers built in 1984 with Carrier Eagle-plus units (SEAU 128367 built 6-84 is an example). Another similar group is a series of Nippon Fruehauf model KARX 40TAJ refrigerated containers with Thermo-King units (examples: SEAU 128605 built July 1984; SEAU 128807 built August 1984 and others between). Lastly, Sea-Land has picked up a bunch of ex American President Line 40' refrigerated containers from the APLU 506010-506809 series built by Nippon Trailmobile in 1976. These are equipped with Thermo-King Sea-Going units. The new Sea-Land numbers are in the SEAU 1255XXs (sighted 125575/125603 so far)

SHIPPERS CAR LINE (ACF) continues adding new "Center Flow" covered hoppers including the series ACFX 59909-59923 PD5000 (pressure-differential 5000 cuft) design (ACFX 59912 built 10-84 by ACF Milton for lease to Windsor Minerals).

Also the first case I've seen of a 5701 design "Center Flow" covered hopper built by the Milton plant is ACFX 36677 built 7-84 for lease to U.S. Industrial Chemical (series ACFX 36621-36740). (EAN/CTB)

A.E. STALEY still continues from last months notes with another build date on the STMX corn syrup tank cars. STMX 475 built 4-85 by Trinity, Longview. By the way, the numbers and the build dates have no correlation in this case. That is higher numbers do not mean later build dates and vice versa. (DGC)

TENNESSEE EASTMAN CO. has purchased some new ACF Huntington built "Center Flow" covered hoppers to add to their fleet. These are the new 5800 cubic foot design equipped with 5135 outlets. Cars sighted so far include various numbers between ETCX 58036 and 58080. Cars were built in March 1985 and are Polyclutch lined by Trinity and Tank Lining Corp. (DGC)

TEXASGULF INC.: In that series TGAX 131400-131533 mentioned in FCJ #9 we've found an additional builder. TGAX 131465 sighted built by ACF, Milton in 1-85 for phosphoric acid service (as the whole series is). This makes three builders for this series: ACF, Richmond Tank and Union Tank. (CWS)

TRAILER TRAIN will be getting at least five articulated double-stack container trains depending on how Santa Fe, Southern Pacific etc. go with their orders. Trailer Train already has a new reporting mark assigned for these double stacks to be designated "DTTX".

Those VTTX rebuilt (former GTTX) skeleton like container cars are showing up with an extra pair of container brackets made by Portec placed in between each of the two pair already on the car. The purpose of this is so the car can now carry 20' containers as well. Originally the cars were marked and could only carry 40' containers. These two new bracket additions allow the car to carry either two 40'ers or one 40'er and two 20'ers or four 20'ers. Not all the cars have these additional brackets (whether this is on purpose or not is presently not known).

We should also mention that Trailer Train continues to overhaul, recondition and repaint TTX, WTTX, TTXW and TTCX prefixed cars. The TTX prefixed cars are especially of note as these are ones that have bridgeplates for circus loading indicate that need is still there. (SHT/DGC)

UNION TANK CAR CO.: Recent additions include some tank cars leased to C&T Refining (UTLX 650062 built 4-85 by Union Tank Car, 20650 gallon).

A group leased to Freeport (with Freeport's logo) built in 10-84. (UTLX 24432 is one of them). In the same series are some leased to OMYA, Inc (stenciled lessee I.D. only). UTLX 24413 built 10-84 is an example.

UTC also built some new tank cars for lease to Mobay Chemicals. These are 20,600 gallon tank cars (UTLX 61464 built 10-84 and lined 12-84 with PL3066 by Lithcote is an example)

And the last of the new cars reported to FCJ this month is a group leased to Amaizo (with their logo) UTLX 600148 built 2-85 and lined by Lithcote 3-85 is an example. (EAN/DGC)

THE CABOOSE COLUMN

CHICAGO, SOUTH SHORE & SOUTH BEND have added some ex- Santa Fe cabooses to their fleet. The cabooses were not renumbered and retain their Santa Fe numbers with only the ATSF obliterated and replaced with "CSS". The ATSF logo was painted in as a solid circle and the "South Shore Line" decal placed in the center of the circle. Numbers sighted are 999008, 999024, 999061, 999096, 999149, 999196, 999257 and 999486. (CWS)

FCJ ADDITIONS AND CORRECTIONS

FCJ #9

- pp.4-6 ADD RBOX 2505 is class XGF88 built by Golden Tye in 1-76 (CWS)
- pp.4-6 ADD also ex- NHIR 743-749.
- pp.4-6 ADD RBOX 1015 still in New Hope & Ivyland green as of May 1985!

THE MISSING GONDOLA END Page 1 of FCJ #8

In reply to those many letters that the editor received asking "where's the end to that gondola on the cover?" The answer is...."its in my desk drawer" However to avoid numerous readers showing up at my door to look in my desk drawer I guess I'll share it with ya...(sorry 'bout that)

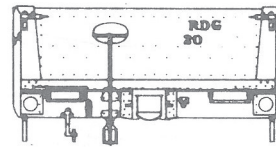

RECENT FREIGHT CAR HISTORY LITERATURE

First of all let's welcome the Union Pacific Historical Society to the scene with their publication "The Streamliner" (see below). Also I encourage readers to please send us a card or letter letting us know about articles in other historical society journal you belong to. We will be expanding this column to include commercial publications as well in the format of a subject index.

METCALFE, TERRY 1985. Livestock Dispatch Rolling Stock. The Streamliner 1:1 pp.5-11. Text, 11 photos, 4 diagrams and rosters. Very nice account of the fascinating livestock cars of the 1930s to 1950s era.

PEACOCK, FRANK 1985. Basics of Freight Cars: Union Pacific Steel Box Car Ends. The Streamliner 1:2 pp.5-9. Text, 14 photos. Aside from the excellent captions and photos...I say BRAVO for Frank Peacock in noting that we as observers sometimes have to make up terms that more aptly fit our needs!!!

READING CO. EIGHT-WHEEL CABOOSE

by Eric A. Neubauer

The Reading built 358 caboose cars to their own designs which were modifications of the USRA design. Of these, 63 were built for related lines. The remaining 295 made up the entire fleet of Reading 8-wheel cabooses except for 20 International extended vision cabooses.

In the list that follows, the built dates given are believed to be accurate. Reading cabooses were shopped and repainted as frequently as 12 times in 40 years! It is not surprising that the built date was not always copied accurately. Many cabooses carried incorrect dates by 1976, and this was also true with the Lehigh Valley.

There has been much discussion of how Reading cabooses were painted. The following is derived from the examination of various photographs and a paint chip from an NMk.

The cabooses were originally red in color throughout. A deep rich red color was original, but Cornell, caboose and boxcar red were also used. There are reports of caboose red cars with boxcar red roofs and end platforms. These probably represent partial repaints. A similar situation existed on the Boston and Maine. Sometime after caboose red was adopted, the roofs began to be painted black. The cupola sides and ends were also painted black in at least one case. By 1955 most cabooses had all railings handholds and kickplates painted yellow.

In the mid 1960's yellow and green was adopted for most freight equipment including cabooses. One car was painted entirely green just before Conrail.

Many minor changes were made to all classes (except NEa and NEb) over the years. The drawing represents 92813 as it appeared around 1956. This car eventually wound up on the Black River and Western by way of the New Hope and Ivyland. It is no longer on the BRS&W as far as I can determine.

The following list includes all changes from the as built condition of 92813:

- Lantern removed from top of cupola and hole patched.

- Smokejack replaced.

- Backup whistles and piping added to both ends.

- KD air brake changed to AB. The original combined reservoir and triple valve was mounted next to the cylinder between the present reservoir and triple valve.

- Wooden end platforms replaced with steel.

- Handholds above lantern brackets added.

- Kick plates added and railings modified above coupler and draft gear.

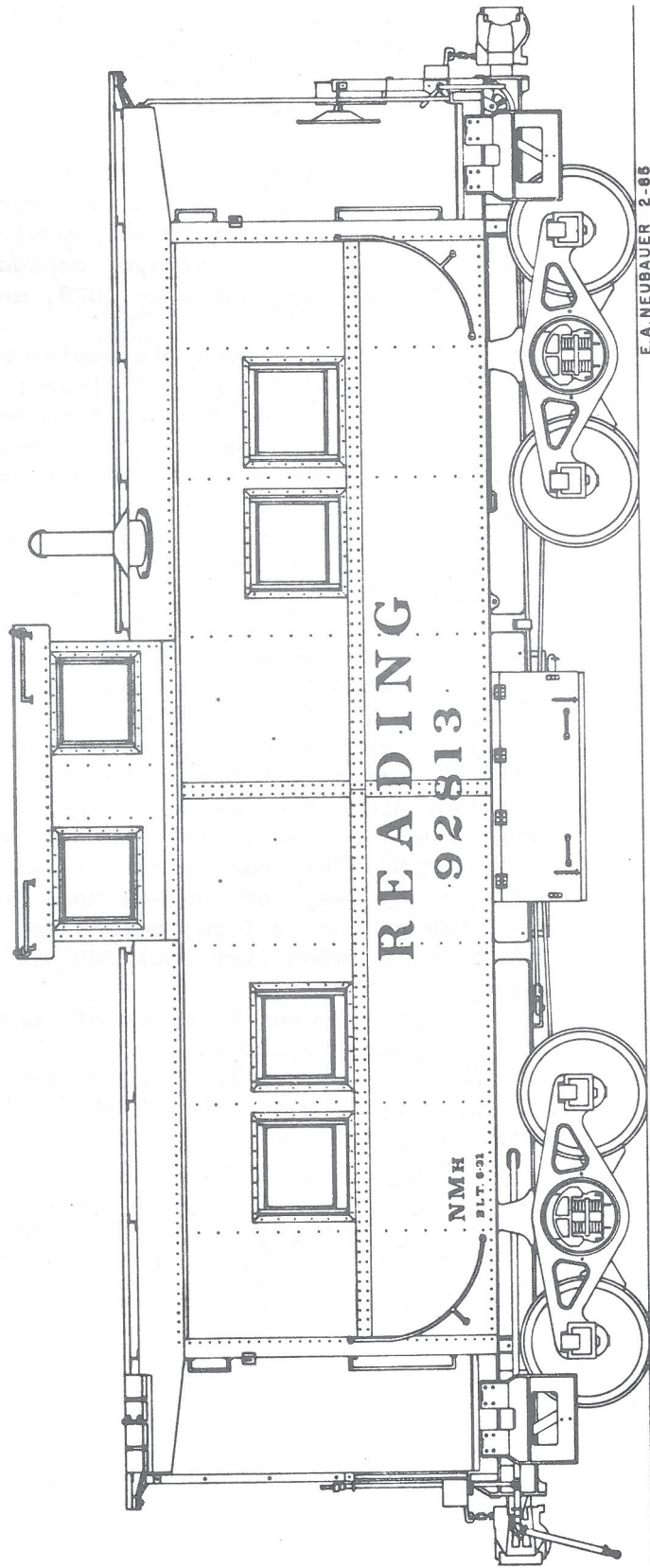
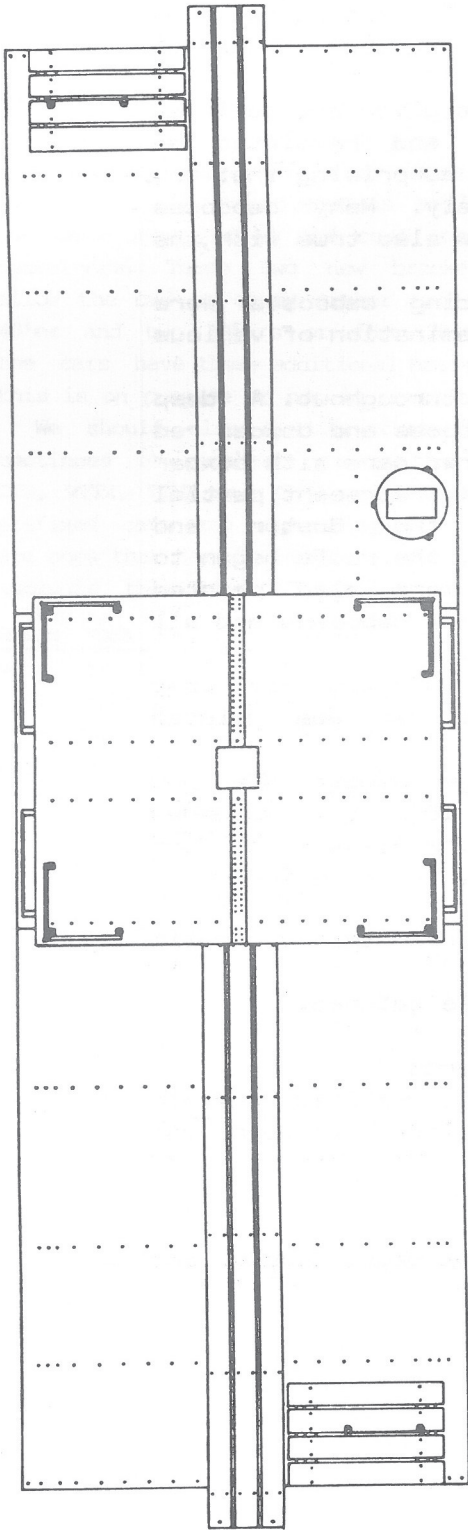

E.A. NEUBAUER 2-86

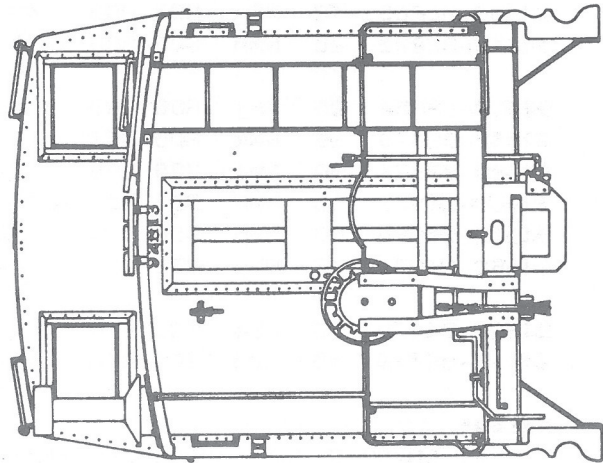
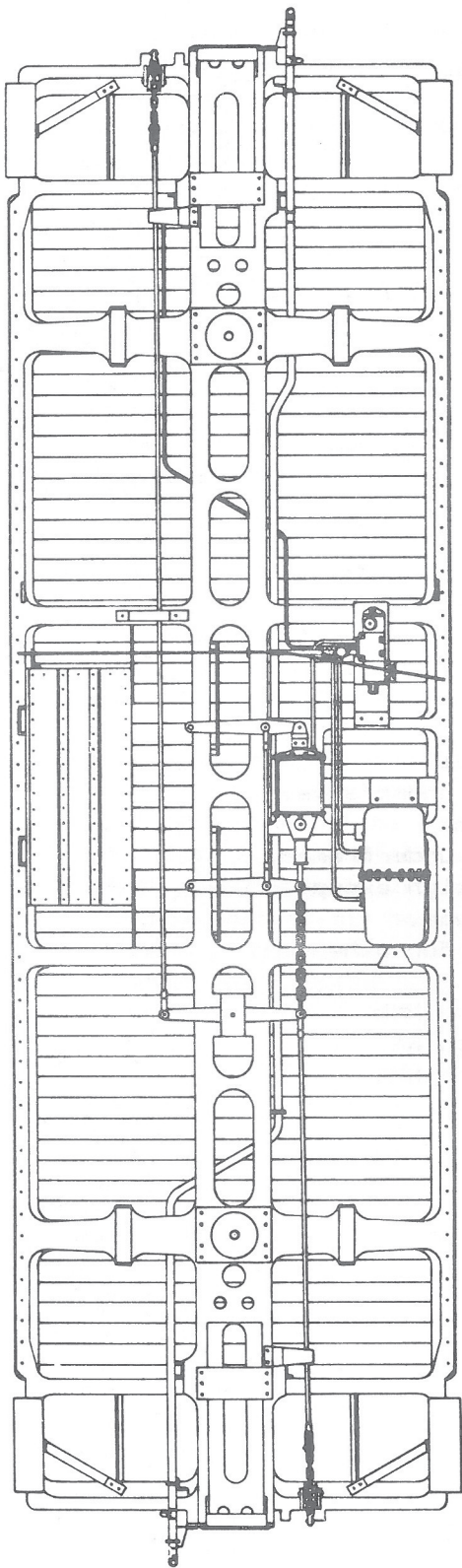

Copyright © 1985 Eric A. Neubauer

READING COMPANY 8-WHEEL CABOOSE

Numbers	Quan	Class	Builder	Date	Trucks
90730-90739	10	NMd	RDG RDG	7=8-24	Arch bar
90710-90719	10	NMe	RDG RDG	5-26	Arch bar
90720-90729	10	NMF	RDG RDG	9=10-27	Arch bar
90700-90709	10	NMg	RDG RDG	2=4-30	Taylor
92800-92809	10	NMg	RDG RDG	4=7-30	Taylor
92810-92829	20	NMh	RDG RDG	5-31=3-32	Taylor
92830-92854	25	NMj	RDG RDG	2=3-36	Cast steel from XMs
92855-92879	25	NMk	RDG RDG	6-37	Taylor
92880-92929	50	NMl	RDG RDG	3-41	Birdsboro
92930-92979	50	NMn	RDG RDG	6,9=10-42	Birdsboro
94000-94049	50	NMo	RDG RDG	7=8-44	Birdsboro
94050-94074	25	NMp	RDG RDG	4-48	Taylor from XMu
94100-94109	10	NEa	ICC KTN	8-70	
94110-94119	10	NEb	ICC KTN	10-71	

Notes:

1. 90700-90739 and 92800-92829 are all steel construction with fixed center sill. 92810-92829 cast steel underframes.
2. 92830-92929 and 94000-94074 are all steel construction with welded Duryea cushion underframes.
3. 92930-92979 are wood sheathed steel frame construction with welded Duryea cushion underframes.
4. All cars are derivatives of the USRA design except 94100-94119 which are extended vision type.
5. The following were built by the Reading for other railroads:

LNE	580-584	5 cars	6-37?	similar to NMk
CNJ	91500-91549	50 cars	4=5-42	similar to NMl
LHR	10-17	8 cars	9-42	similar to NMn

THE MODELER'S COLUMN PRESERVATION IN SCALE

by BYRON S. ROSE

Since I haven't been scalped after my first column, I'll take a chance on a second; who knows, this may become a habit.

I thought I'd use this month's column to present an overview of the H.O. scale freight car modeling scene today, and express a couple of opinions. In no particular order:

GRANDT- State of the art in injection molded kits of any and all hobbies, but unfortunately for us of broad gauge persuasions, only models narrow gauge equipment--superbly! If only other manufacturers would learn from Cliff Grandt's example, freight car modeling would be as popular as airplane modeling.

GOULD- Runner-up to Grandt in injection molded kits, but does have several flaws. Goulds kits are excellent generic models, but unfortunately miss 100% prototype accuracy, admittedly by very little; but I'm a 100% person. I will probably never build one of their tank cars with the oddly proportioned tank in the kit. I have my fingers crossed that the forthcoming reefer and USRA box car will avoid these problems, all Gould has to do is ask and correct information will be available.

WESTERFIELD- State of the art in non-injection molded kits. Al Westerfield has to be one of the most unselfish modelers in the hobby today, for sharing with us his scratchbuilding talents by literally reproducing each part necessary to build an exact reproduction of a given prototype. I have just finished building one of his PRR GL hopper cars, and except for some missing decal lettering it is a rivet for rivet copy of the prototype in the Pennsylvania Railroad Museum. Westerfield has also broken out of the "rut" of similar cars, copies of copies, etc., by bringing us such jewels as the USRA triple hopper, the Heinz "coffin" pickle car, and the Pressed Steel Car Co. hopper series. His next car however, will be familiar to anyone who built Ambroid kits in the 50's and 60's, but with all the bolts and rivets that Ambroid left off.

DENNIS STORZEK- A new arrival on the kit scene, producing kits similar in concept to Westerfield, but including some cast metal parts, especially one of the nicest caboose underframes I've seen (see, it doesn't take much to get me excited). If Dennis could eliminate the minute bubbles that mar some of his castings, his kits would equal Westerfield's. As it is, his Murphy end

boxcars have proven to be quite useful, there seems to be one in the background of almost every 30's and 40's era photo I've looked at recently.

ROLLER BEARING MODELS- Now under new ownership, hopefully they will get their act in order and not waste everybody's time on castings made from cardboard patterns. Actually, their tank cars are very good kits; it helps to have a prototype photo handy to see what the ladders, railings, steps, etc. really look like.

ROBIN'S RAILS/ E&B VALLEY- a perfect example of the "fatal flaw syndrome". When Gould was making the dies for some of their narrow gauge cars they were excellent. Since then most of their models have had a fatal flaw. Mill gondola-too light, underframe geometry all wrong-fatal! Airslide hopper -ends all wrong- detailing off, grabs don't line up with sides-fatal! Of course anyone who tries bringing out the AHM hopper as new, and clouds the issue by advertising it with a photograph of another version of the P.S. car deserves his fate. I have just seen the Greenville 60' parts car and it appears to suffer from oversize rivets- will they ever learn?

Of course we still have some dinosaurs among us, companies whose products were state of the art in the 40's and 50's (and maybe 60's) but look archaic today. You know the ones I mean, they used to be Ambroid, Quality Craft, La Belle, Red Ball, Silver Streak, Ulrich, Suncoast and others too numerous to mention. These kits are still available today, under different names perhaps, but still the same old tired models. WHY? you might ask. Okay, I'll tell you. Styrene, polyester and cyanoacrylate, that's why. It makes no sense today to build a metal car out of wood and/or cardboard with the need to seal, sand, seal, sand.....to eliminate the wood grain and fuzz. Even wood siding makes no sense once you've tried building a car with Evergreen scribed styrene. If you are one of those who enjoys fuzzy wood siding, grained metal, and rivetless rivets--fine! But, if you like freight cars that look like miniatures of the real ones, you will be replacing all that "beautiful" Northeastern scribed basswood with the even more beautiful Evergreen scribed styrene and sell the rare kit for 20 bucks after you've built the model.

I find it very disheartening to see these fine old firms, or their new incarnations, continuing along the same paths. Perhaps if they saw how easy the new technology can be used, we would all benefit from it.

There are a couple of kit producers the jury is still out on, DETAILS ASSOCIATES being one.

They are rumored to be working on a G.S. drop bottom gondola, and if the few parts they've released are any indication, it's "move over Gould" time! MCKEAN has some flaws such as the sink marks on the hoppers, and poor choice of cars for the 40' auto car (unless you are a GN fan who likes overdone underbodies) but shows potential. DETAIL WEST'S first cars were excellent, whats next?

And ATHEARN and MODEL DIE CASTING are, at best, Athearn and Model Die Casting. The time is ripe for conversion kits to hit the market to convert their models into something more useful than they are. After all, how many railroads had B&O's 4 bay offset side hopper? Who will be first?

That brings us to B R A S S, in neon lights, on a background of green. I guess that as long as there are no kits available for Flexivan, PD 4000s, B&O wagontops, snowdozers and enclosed auto racks there will be a need for brass models. What I can't figure out is where's the need for brass ATSF cabooses, PRR X-29 box cars, and Russell wooden snow plows. I will try to cover brass models in an upcoming column, as soon as the shock wears off.

I hope I have contributed some to your fund of knowledge of Freight Car Modeling. And I think this issue's column should have stirred a few people's emotions.....so remember you can get your two cents worth in to me at P.O. Box 11805, Pittsburgh, PA 15228.

WITH our next issue we'll be adding a column dealing with real freight cars that have by some miracle escaped the scraper's torch. That is freight cars which are, for want of a more descriptive word-preserved. This will include cars in museums, parks, private ownership etc. We'll establish a format which will basically include the car's reporting marks, number, car type, date built, builder, condition of present car and location. As well as significant historical notes.

This will be a column that will be written by you our readers though. So, museums....let's hear from ya!

We hope to encourage a certain amount of dialog regarding published information and hope that corrections and additional information will be sent in; after all, we can only be as accurate as the help we get.

FREIGHT CAR LOCATER

Edited by RICHARD YAREMKO

The purpose of this column is to identify those locations where freight cars are currently being stored waiting to be scrapped or placed back in service. Focus will be on those cars that can either be classified as "fallen flags" or those cars whose age is a determining factor in their return to service. We hope this will prove valuable

to FCJ readers planning railfan trips or vacations. Information is only good when current so we ask that you make contributions and send them to Richard Yaremko, 116 Deercross SE, Calgary, Alberta Canada T2J 6G7. Format should be by railroad and include yard and city point reference. A brief description of what can be spotted is also required.

BURLINGTON NORTHERN - Minneapolis, Minnesota. Site of a scrapping operation. Storage and scrapping takes place at a yard located just north of numerous large grain elevators near University Ave. and 30th Ave. between Minneapolis and St. Paul. Lots of GN, NP, CB&Q, SPS and BN equipment.

CANADIAN NATIONAL - Toronto, Ontario. Storage yard containing older CN equipment including wood single sheathed boxcars, work equipment, and tank cars (some from 1920s) can be found north of Gerrard Street east of Main Street in the east side of Toronto.

Another yard contains old and damaged CN equipment is located at the south end of MacMillan Yard, south of Highway #7 between Jane street and Keele Street on the Northern edge of Toronto. All types of CN equipment can be found here waiting to be moved to London, Ontario for scrapping. Yard has about 12 tracks a ¼ mile long and is always full.

CONRAIL - Niagara Falls, New York. Pre- CONRAIL equipment such as PC, PRR, NYC, EL and LV can be found on the south tracks of Black Rock Yard in the central area of Niagara Falls.

- Above is all courtesy of John Riddell -

CONRAIL - Buffalo, New York. the old west yard tracks on both sides of the filled in slip are now used to store CONRAIL and predecessor out of service and surplus cars, mostly XM, XF, XLI, and RBL types used in the Buffalo flour mills. Many PRR, PC, EL, LV, BCK 40' and 50' to be seen. The center and west yard tracks are still in use serving Pillsbury and other mills and elevators. Plenty of CR/PC/PRR and ATW airslides, XF and RBL's. Also scores of CR/PC X72A Evans built cars (Lifelike model). The west yard has recently been cleaned out of brush and old tie piles so photography is easy. Access is from Fuhrmann Blvd. west, under Rt 5 Skyway overpass along track. Good down on shots can be taken from Route 5. - Courtesy of James Eager

Please remember its as important we get the data thats stencilled on these cars written down as well as photographs.....they won't be here much longer.....

**BUILDER'S PRODUCTION
AND DESIGN NOTES**

The hot new designs still focus primarily on intermodal equipment, but a few new covered hopper designs are coming out as well. Still no boxcars reported as new built. With piggyback trailers getting longer and wider the cubic capacity of these rubber tire boxcars gets nearer to that of the steel-wheeled cousins. The newest length is the 48' piggyback van with a cubic capacity around 3400 cuft. The Seaboard and Norfolk Southern System are reportedly the first U.S. railroads to take advantage of this new length.

With that lets take a look at some news from the builders.

GUNDERSON INC. has purchased FMC Marine & Rail which became effective March 1, 1985. So FMC is out...Gunderson is in. Note that Gunderson was the original name that later became FMC in the Seventies.

Anyway Gunderson along with Greenbrier Leasing has introduced a new design articulated double-stack well type container car. This new car like its Budd-designed, Thrall built, APL operated cousin can only carry 20' containers on the lower part of the two end units (max. four 20'ers). It is also stencilled that it can only carry 45' containers on the top part of the two end units. the three middle sections are stencilled 40' containers only. The major difference in this new car versus the APL cars is the presence of bulkhead like structures on each end of each unit. The bottom container can hardly be seen. These too are five-unit cars but are a little heavier than their APL relatives weighing out at approximately 164000 lbs (versus the 155000 of the APL cars). Lastly, we should note that Gunderson calls these "Twin-Stack" (Trademark).

AMERICAN CAR & FOUNDRY introduced a new larger "Center Flow" covered hopper apparently to compete with the Thrall, Richmond Tank and Pullman counter parts. The new car has a capacity of 5800 cubic feet. It has four hoppers. The two end hoppers have a 1590 cuft capacity, while the two center hoppers have a 1310 cuft. capacity.

TRAILER TRAIN is reportedly working on a three-unit well type car that will accept either piggyback trailers or double stacked containers.

GENERAL AMERICAN is going to be introducing a newer, larger 4900 cubic foot Airslide covered hopper. (Previous sizes have been the 4566 cuft, 4180 cuft. and the 2600 cuft. designs.

**UTILITY FUELS, INC.
ALL TIME FREIGHT CAR ROSTER
1978-1985**

Utility Fuels Inc. has acquired new from the builders a total of 2530 rotary-end coal gondolas during the past eight years. All cars have fixed sides and ends, solid bottoms and operate in unit train service apparently on the BN. Home point for these cars is Colorado Springs, Colorado and their offices are in Houston, Texas. See photos on back cover. Reporting marks are UFIX.

<u>Road Numbers</u>		<u>Dates Built</u>	<u>Design</u>
1001-1110	(110)	2-78	BFF
2001-2110	(110)	3-78	BFF
3001-3110	(110)	4-78	BFF
4001-4110	(110)	6-78	BFF
5001-5110	(110)	6-78	BFF
6001-6110	(110)	8-78	BFF
7001-7110	(110)	8-78	BFF
8001-8110	(110)	1978	BFF
9001-9110	(110)	10-78	BFF
10001-10160	(160)	11-78	BFF
11001-11110	(110)	3-79	BFF
12001-12110	(110)	?	BFF
13001-13110	(110)	9-80	ACF
14001-14110	(110)	10-80	ACF
15001-15110	(110)	11-80	ACF
16001-16170	(170)	11=12-80	ACF
17001-17110	(110)	12-80	ACF
18001-18110	(110)	12-80=1-81	ACF
19001-19110	(110)	3=4-81	BFF
20001-20110	(110)	4-81	BFF
21001-21110	(110)	1981	BFF
22001-22110	(110)	5-81	BFF

DESIGNS:

BFF: The Berwick (or Whittaker) design cars. All of these are 46'10" inside length cars with a cubic capacity of 4200 cubic feet. The cars have a light weight of about 51,000 lbs. These cars are painted black with white data and orange rotary ends. It does appear as though Model Die Casting's 50' Bathtub Gondola (#1660) H.O. scale model is nearly identical to this car.

ACF: American Car & Foundry's version called the "Coalveyor" (Trademark). These cars are 48'0" inside length and have a cubic capacity of 4240 cubic feet. These cars too are painted black with white data and orange rotary ends. As far as I know there are no models in H.O. or N scale of this car.

FMC PORTLAND PRODUCTION LIST Part 6

<u>JOB NO.</u>	<u>P.O.</u>	<u>BUILT IN YEAR</u>	<u>QUANT.</u>	<u>CUSTOMER AND DESCRIPTION</u>	<u>CAR NUMBER (SERIES)</u>
17968	HU	1979	150	MAINE CENTRAL 100-ton box car, 50'-6", single sheathed, single 10' sliding door, centered on centerline, 20" sliding sill, Plate C, 10'-11 7/8" I.H.	MEC 20000 - 20149
17975	IG	1980	1000	BURLINGTON NORTHERN 100-ton covered hopper, 4,700 cu. ft.	BN 460200 - 461199
17977	HS	1978	150	MAINE CENTRAL 70-ton box car, 50'-6", single sheathed, single 10' sliding door, centered on centerline, 10" EOCC, C-PEP, Plate C, 11'-1 3/4" I.H.	MEC 31750 - 31899
17978	HV	1979	150	NEW HOPE & IVYLAND 70-ton box car, 50'-6", single sheathed, single 10' sliding door, centered on centerline, rigid, Plate C, 11'-1 3/4" I.H., Hennessy door closer, XM	NHIR 5001 - 5150
17979	HQ	1978	150	ITEL 100-ton box car, 50'-6", single sheathed, double 8' sliding doors, centered on centerline, 15" EOCC, Plate F, C-PEP, 12'-10" I.H.	*VS 2000 - 2149
17980	HR	1979	100	ITEL 100-ton box car, 50'-6", single sheathed, double 8' plug door, centered on centerline, 15" EOCC, Plate F, C-PEP, 12'-10" I.H.	**MDW 6000 - 6099
17983	IH	1979	100	WESTERN PACIFIC 70-ton box car, 50'-6", single sheathed, double 8' sliding doors, centered on centerline, 10" EOCC, (Freight Master and ACF) Plate B, 10'-7" I.H.	WP 38126 - 38225
17985	ID	1979	200	HARVEY 70-ton box car, 50'-6", single sheathed, single 10' sliding door, centered on centerline, 10" EOCC, Plate C, 11'-1 3/4" I.H.	***CAGY 21000 - 21199

*Valley & Siletz R.R. Co.

**Minnesota, Dakota & Western Ry. Co.

***Columbus & Greenville Ry. Co., Inc.

SOUTHERN PACIFIC TRAIN CONSISTS

Part I: CZLAT Trains

By Pat Holden

INTRODUCTION

Throughout the railfan and railroad history literature there are numerous references to particular "trains", symbol trains, name trains etc. Many times the type of locomotive is mentioned and sometimes specific numbers are listed. Several sources document passenger train consists. But what of the freight car? Seldom is the numerically largest vehicles on the rails ever described in the various reports. I often wonder if the freight car really does exist in the railfan literature or if its just an imaginary creature that mysteriously appears behind the locomotives in a 3/4 headon photograph.

Freight trains take on their own special character too. The various regular route trains carry specific products and as a result certain kinds and types of freight cars are used. Thus in many cases the particular freight train is characterized by particular freight cars. With that in mind lets take a look at our first train.

C Z L A T

CZLAT trains, designating Crown Zellerbach to Los Angeles Trailers, are a prime mover of that most important commodity into the L.A. area which we all use daily called toilet paper. Also these trains haul much of the newsprint and fibreboard boxing that is consumed in the area and some of the lumber for the building industry. As a result of its cargo, it has recieved other names by its operating crews such as the T.P. Train or T.P. Express and some others not suitable to be repeated here.

Based on a survey of these trains over the period from January 1984 to January 1985, the following trends have been observed about these trains:

1. They consist of from 30-75 cars usually all loaded.
2. They usually weigh 2500 to 6500 tons depending on their length which varies from 1900 to 4800 feet.
3. They have predominantly S.P. rolling stock with a large number of double-door boxcars in them.
4. They do not have to have any trailer flats to be designated CZLAT as about a third of them have no such flats in the consist.
5. They seem to have enough power on the headend so that they often do not need helper power and make fairly fast time over the rails.

Based on observation, these trains are somewhat localized as evidenced by the lack of much foreign rolling stock in the consist from Union Pacific or Burlington Northern. Some trains consist almost entirely of SP/SSW boxcars which indicates an origin of no further than Oregon. Generally, the trains run (or nearly run) on a daily basis using either the California "coast route" or the "valley route" over Tehachapi.

Probably the best way to illustrate the train's consist is to list, from a composite of my sightings a typical, hypothetical train as follows. **POWER:** Typical stuff include SP 9037, an SD-45; SP 9312, a SD-45T2; SP 7327, a SD-40E and SP 8295, a SD-40T2. Total power is about 13,200 horsepower.

CONSIST:

SP 248592, a 52'8" end-of-car (EOC) cushioned double-door general-service box car (AAR designation XM) made by Pullman-Standard in 1979. This is one of the "class 80s" (SP class B-70-84) boxcars delivered in 1979-80. This class has Freightmaster EOC cushioning and Youngstown corrugated sliding doors. Construction on this class as well as the other three "Class 80s" series is welded with external posts.

SP 240489, a 50'7" underframe cushioned double-door general-service boxcar made by Gunderson in 1972. This is from one of the largest classes of XM boxcars the SP has with some 2900 cars spread between two series. This one has Youngstown corrugated sliding doors and Hydra-Cushion 20-14A cushioned underframe.

SP 246427, a 52'8" EOC Cushioned double-door general service box car. Another of the four "class-80s" series. This one is built by FMC in 1979. It also uses Freightmaster EOC to cushion its cargo.

SSW 62748, a 60'10" cushioned underframe high-cube general-service boxcar. The "giant behemoth" of this train is this 7477 cubic foot capacity 100 ton plate F+ box, built by Pacific Car & Foundry in 1979. This car as well as most of the other boxcars in this train is also carrying paper.

SSW 23686, a 50'6" cushioned underframe single plugdoor 70 ton RBL (a passive/non-mechanical refrigerator or heavy-insulated boxcar). This one was built by Pacific Car & Foundry in 1974. It features a wide-door 14' Youngstown plug opening and has special Air Bag load dividers inside to help secure the load. Riveted panels with interior post construction differ this car.

SP 16882 and SP 13118, both are 50'6" uncushioned single door general-service boxcars. These are a couple of the several ex-Railbox cars acquired by the SP in 1983. See photo.

SOU 531589, a 50'6" uncushioned single-door XM. One of the few foreign cars in this train, this Southern car comes from a series of 500 built by Pullman-Standard in 1979. It has a 10' P-S sliding door and differs from all of the previous cars by having waffled sides.

SBD 10382, Another ex-Railbox car. This one is one of the 1000 acquired in 1983 by the Seaboard System.

SP 248600, like SP 248592 above is another 70 ton double-door box. See also photo.

RBOX 35270, One of the Railbox cars that escaped relettering. this one built by Pullman-Standard in 1979.

SSW 88342, a 60'7" EOC Cushioned 100 ton bulkhead flat car built by Thrall Car in 1979. The car has 18 pockets for stakes and features welded construction with a straight side-sill and steel bulkhead. Class F-100-18. This guy is carrying lumber.

SP 240134, Another like 240489 above is a 70 ton double door box. See also photo.

SP 19103, another ex-Railbox car. This one built by FMC though.

WCTR 102525, a 50'6" cushioned double-door 70 ton XM built by Berwick (Whittaker) in early 1980. The car has Youngstown corrugated sliding doors and Keystone 15" cushioning. Offers a slightly different shade of "brown" to the consist.

SP 565727, a 53'6" 70 ton general-service flat car. SP Class F-70-55. Built by American Car & Foundry in 1970. This series has 16 stake pockets with a straight welded side-sill and wood floors. Car is carrying board lumber.

SP 203938, a 50'6" uncushioned double-door 70 ton general-service boxcar. SP Class B-70-37. Today a relatively rare series (40 cars). These have double Superior panel sliding doors and were built in late '66 early '67.

WLO 528141, a 50'6" uncushioned single door (10') 70 ton XM. Finally some color other than SP Brown and Railbox Yellow, this orange car was built by Illinois Central's shops with kits supplied by Youngstown Steel in August 1979.

SSW 85204, a 53'6" uncushioned 70 ton general-service flat car. SSW Class F-70-52. Built by Thrall Car in 1969. This flat differs from the SP 565727 listed above by having a drop-center side-sill also of welded construction. It too has 16 stake pockets and as one can see in the photo....its carrying lumber.

SP 246835, a 52'8" EOC cushioned double-door 70 ton XM box. The third of the "class-80s" series. This one is built by Pacific Car in 1979. Class B-70-82. This class as with the other three "Class-80s" cars have exterior post design with double 8' corrugated doors.

SP 243628, a 50'7" cushioned underframe double-door 70 ton XM box. Class B-70-71. Built by Pacific Car in later 1973. These cars have Superior panel 8' sliding doors.

SP 247305, a 50'8" cushioned double-door 70 ton general service box (XM). The last of the four "Class 80s" series. This one built by American Car & Foundry (ACF) in early '80. Class B-70-83. The car features Freight Saver cushioning and double 8' Youngstown corrugated doors. ACF lot number 11-06858. See also photo.

SP 16701, another 50'6" single-door ex Railbox car. This one built by Berwick in 1976.

SP 248248, another double door box just like the first car listed, SP 248592 and like the photo of 248600. This is one of the "Class- 80s" series. By the way, these Pullman-Standard cars of this class have a different type of roof than other "Class 80s" series. These cars have a "low-pitch" (looks like its flat) roof.

BN 621498, a 56'8" cushioned 100 ton bulkhead flat car. This series was built by Thrall car in 1976 and is carrying lumber. A nice "splash" of green in a sea of brown...

SSW 87972, a 60'7" EOC cushioned 100 ton bulkhead flat car built by Thrall in 1975. SSW Class F-100-11. The car features Freightmaster cushioning for its load of lumber.

SP 290055 and SP 291369, a couple of 50'6" cushioned underframe 70 ton general-service insulated boxcars (XMI). These are two of a block of four (see below) of XMIs. These cars usually not for paper service, but in this case may have been available and were loaded with tissue. The cars of this series (290000-291734) have a single Superior 10'6" plug door. The series was built in late 1966/ early 1967. Many of these were rebuilt in 1978. These cars have riveted construction.

SP 291911 and SP 291859 are a couple of 50'6" cushioned underframe double plug door 70 ton XMIs similar to the two above. SP Class B-70-44. These were built in early 1969 and many rebuilt in 1979. Like the above series they have riveted construction, but these have two 8' plug doors. Also, an interesting feature on these cars are the four corner vents. Like its relatives in the above SP 290000 series these too are carrying tissue bound for L.A. use. This series as well as the one mentioned above have "flat-tops" (roofs).

SP 508807, a 57'0" uncushioned 70 ton bulkhead flat car (Stencilled FMS though) built by American Car & Foundry in early 1972. The car has 17 stake pockets with a welded construction drop-center side-sill and wooden floor and wood faced bulkhead. The load is lumber.

SP 247100, another "Class 80s" series car. This is one of the Pacific Car built ones like 246835 above. This one however, has "Bozo Texino's" trademark on the side.

CLC 3489, a 52'6" EOC cushioned offset double-door 70 ton special-product boxcar (XP) built by Pacific Car in late 1979. This is (surprisingly) the only special products box car on the train specifically designed for paper products haulage. It features double offset 8' Youngstown plug doors.

L&N 480154, a 50'6" uncushioned single-door 70 ton general-service boxcar (XM) This waffle sided car was built by Pullman-Standard as part of lot 9786 in late 1974

SP 248141 and SP 248500, Some more of those 50'8" double door "Class-80s" boxcars.

SSW 66004, a 50'7" cushioned underframe double-door 70 ton general-service boxcar (XM). SSW class B-70-67. Built in 1973 by FMC. The car features Hydracushion underframe and Superior panel double sliding doors.

SSW 20386, a 50'6" cushioned underframe double-door 70 ton boxcar. Here's an interesting car. Its probably the oldest one run on this train, being built in 9-62. It also has a flush 8' plug door with its 8' sliding door. SSW class B-70-16.

SP 19153, another 50'6" single-door ex Railbox 70 ton boxcar. This one is a little dirtier than the others though...

SP 243629, is another 50'7" double-door box just like SP 243628 mentioned above.

SPFE 451056, a 50'9" cushioned underframe single 9' plug door mechanical refrigerator car (RPL) (a genuine reefer). The car is equipped with load dividers and this one was hauling potatoes.

TTX 250132/AKLU 290822/REAZ 250051, an 89'1" intermodal flat car with a "K" Line container and a Transamerica Transportation 45' galvanized steel piggyback van.

TTX 153358/AVAZ 256237, a 89'0" intermodal flat built in 1966 with an Availco 45' piggyback van.

TTWX 979660/BNZ 931297/SPLZ 936463, an 89'4" intermodal flat with bridgeplates removed and modified to carry two 45' vans. BNZ 931297 is a 45' van equipped with special floor rails and SPLZ 936463 is also a 45' van with special

recessed restraining floor channels. Both vans are the newer larger 102" wide types.

TTX 603858/VIRZ 254256, an 89'0" intermodal flat built in 1973 by American Car & Foundry. VIRZ 254256 is a Vermont Railway 45' piggyback van. Notice that the TTX cars can accept only accept one 45' van.

SP 900147/BCCZ 250656/SPLZ 250157, a 89' intermodal flat built in 9.65 as an autorack, converted in January 1983 to carry piggyback vans. BCCZ 250656 is a privately owned trailer of the Boise Cascade Corp. SPLZ 250157 is a standard 45' piggyback van of the Southern Pacific.

SP 244302, a 50'7" uncushioned double-door 70 ton general-service boxcar (XM), built by FMC in early 1974. Class B-70-73. Has double 8' Youngstown corrugated sliding doors.

CABOOSE: SP 4755 from the last SP caboose order. built by Pacific Car & Foundry in 1980. Class C-50-9.

CONCLUSIONS

As one can see, probably the two most common groups of cars in these trains are the "Class-80s" series 70 ton double door boxes and the ex-Railbox single door 70 ton boxcars. In addition, I noted the general lack of covered hoppers, gondolas and tank cars. Also note the age of these cars as generally fairly recently built.

Unless it was otherwise noted all cars carried either newsprint or tissue (a few with fibreboard) To keep this consist interesting and note what diversity is present over many trains, I have included more foreign rolling stock in the consist than is usually found on any one train. Of the foreign rolling stock, the Southern and Seaboard systems seem to be the best represented.

Personally, I find these trains are some of the most boring in existence for a watcher due to that lack of diversity....unless of course you're a Southern Pacific 50' double door box car fan!

In the next article in this series, we will see more diversity when we explore the consist of the Southern Pacific Symbol Trains SECIY and see how they differ in their makeup from the CZLAT.

ABBREVIATIONS

SSW= St.Louis Southwestern Railway Co.

SP= Southern Pacific Transportation co.

SOU= Southern Railway WLO= Waterloo RR Co.

SBD= Seaboard System WCTR= WCTU Rwy Co.

L&N= Louisville & Nashville (now Seaboard)

BN/ BNZ = Burlington northern

TTX/TTWX=Trailer Train CLC= Columbia & Cowlitz

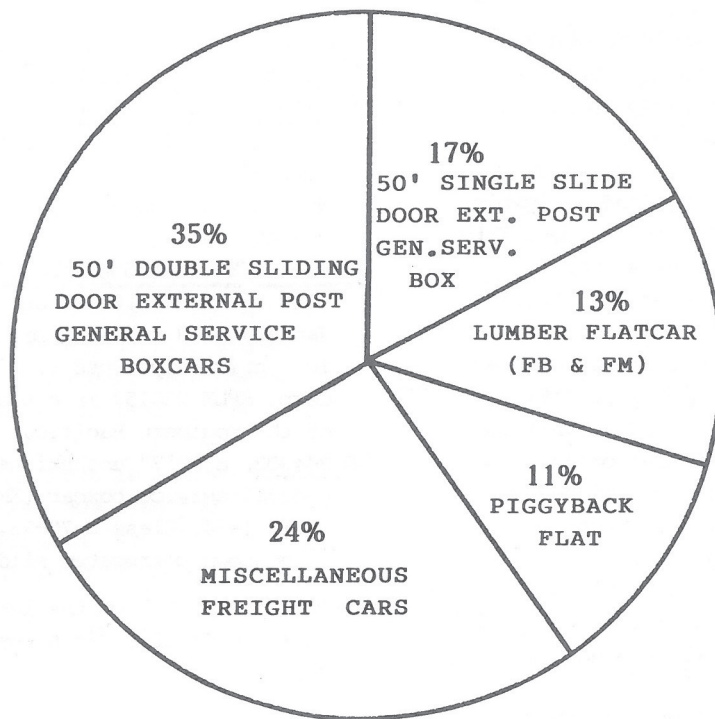
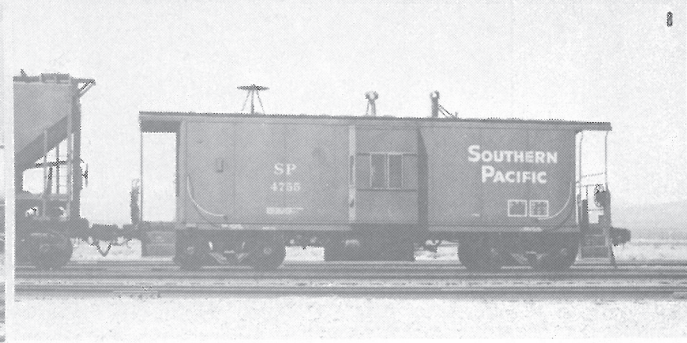
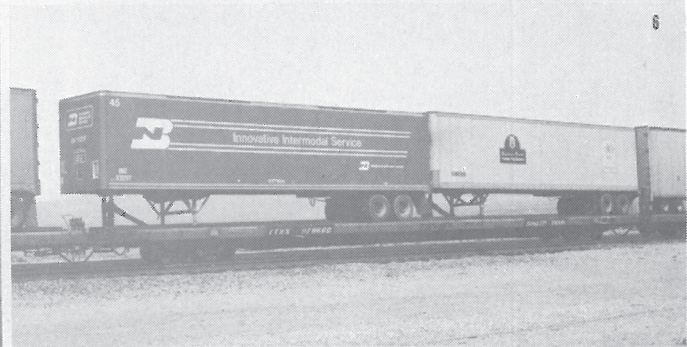
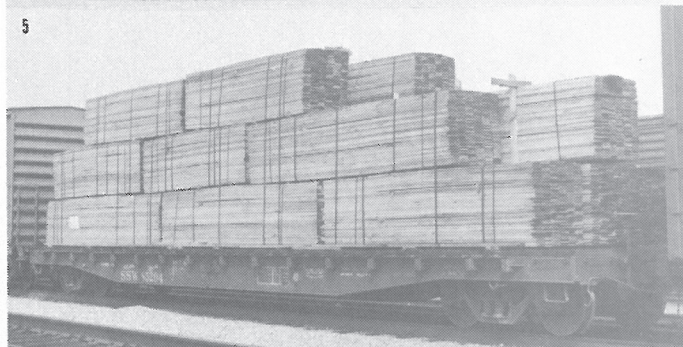

Figure 1.
Approximate
PERCENT
COMPOSITION
of the
CZLAT

MODELLING THE CZLAT

Modelling the CZLAT in H.O. Scale is a bit difficult, primarily due to a lack of appropriate external post double door boxcars available. Only Model Die Castings FMC 50' Double-door box (#1980) comes close. I find it rather depressing that one of the most common trains from one of America's largest railroads has so few representatives in H.O. Scale. The only cars in this train that have descent representatives in H.O. Scale are the Railbox cars and the 60' Bulkhead flats. In the table below I've listed the several kits available and have rated the kit-to-prototype closeness as follows. (I) Replication - A good scale REPLICA of the prototype. (II) Approximation - Having the major physical characteristics of the prototype. (III) Simulation - generally looking like the prototype but having one or more major character flaws. Please remember this is a completely SUBJECTIVE evaluation.

Model Die Casting #1980 FMC 50' Double-door Box	III	Closest in appearance to the FMC "Class 80s" boxes but too short, incorrect post number etc. Simulates others to a lesser degree.
Model Die Casting #1300 60' Bulkhead Flat	II	Close kit. Works for the Thrall F-100-11 and F-100-18 bulkhead flat cars in this train.
Athearn #1399 50' Flat car	III	Simulates the general service drop-center sill flats. Incorrect no. of pockets and rivet const.
Athearn #5520 50' ACF Outside Braced Box	II	A likeness. Few minor measurements and details lacking. Can be used for some of the Railboxes
Roller Bearing Models #401 50' Pullman Standard Box car	II	A good one for the Pullman-Standard Railbox boxcars.
Roller Bearing Models #206 Waffle Side Box Car	III	Can simulate the Waffle-sided boxes in this train, but has incorrect door type etc.
Athearn 85' All-purpose flat #2015	III	Too short but simulates TTX 603858. Top with Durango Press DP-103 and/or R.A. Boyd Containers
Athearn 57' Mechanical Reefer # 5460	II	Good for the SPFE mechanical reefer on this train.



SOUTHERN PACIFIC'S CZLAT

(l.to r./t.to b.) 1) SP 9037 EMD SD45 2) SP 16882 an ex- Railbox uncushioned single door boxcar. 3) SP 240134, from one of the SP's largest class of double-door boxcars. 4) SP 248600, class B-70-84 box built by Pullman-Standard. Note number of posts and side sill architecture. 5) SSW 85204, general service flat car built by Thrall. Note angle of drop on side sill and method of securing lumber stacks. 6) TIWX 979660, modified to handle two 45' trailers. Both the BN and SP trailer have special securing apparatus. 7) SP 247305, ACF's version of Espee's "Class 80s" series. Note major differences in side sill architecture and number of posts. Compare to photo 4 above 8) SP cab 4755, one of the last caboose orders by SP. Class C-50-9. Built by Pacific Car & Foundry (International Car). Photo 1. by Pat Holden. Photos 2-8 by David G. Casdorff

UTILITY FUEL'S COAL GONDOLAS

(REAR COVER-next page) TOP: UFIX 17055 built by ACF in 1980. Black gondola, white data and orange rotary ends. Note 6 major/ 6 minor side post construction. BOTTOM: UFIX 3013 built by Berwick in 1978. Livery same as above. Note 6 major and 9 minor side posts construction. Both photos by J.R.Quinn in Denver, Colo.

